

**TECHNICAL INFORMATION**  
**ALUMINIUM PROFILE**  
**SYSTEM 40 - SLOT 8**

---



---

Information in this document is subject to change. Owing to continued product development, Rollco reserves the right to make alterations without prior notice. Every care has been taken to ensure the accuracy of the information, but no liability can be accepted for any errors or omissions.

All information and content included in this document, such as text, and images, are property of Rollco. Any reproduction, even partial, is allowed only by written permission by Rollco.

# Aluminium Profile Overview

This is the most frequently used profile range, suitable for machine stands and machine covers. The range includes different versions and all profiles are interchangeable.

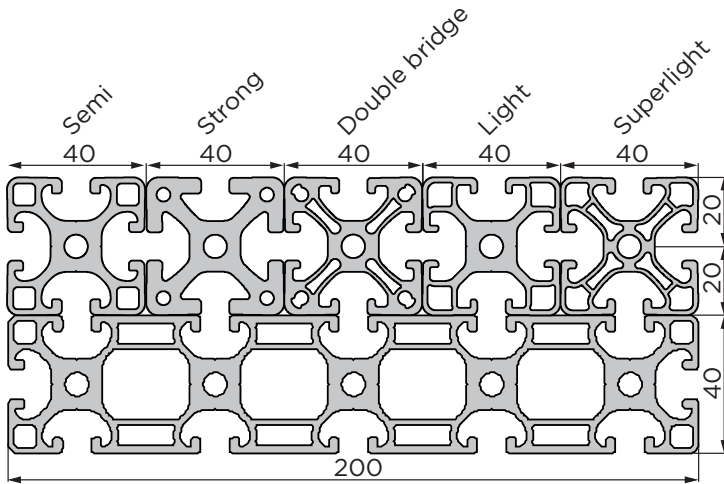

- T-slot 8
- Center hole for M8

**Semi**

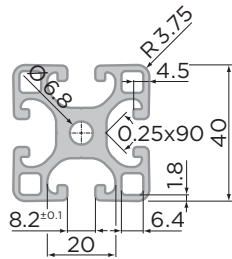
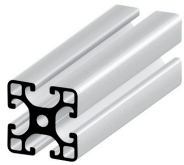

**Strong**

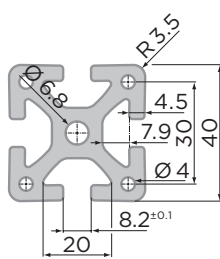

**Double bridge**

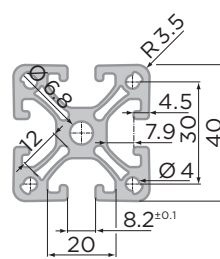

**Light**

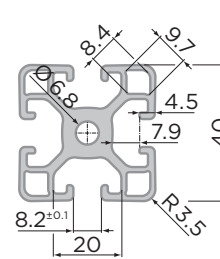

**Superlight**

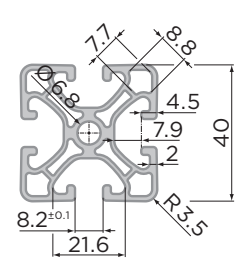

# Technical Data

## Extruding Press Profiles

(according to DIN EN 12020 part 2)

<b>Alloy</b>	Al Mg Si 0.5 F25
<b>Material No.</b>	3.3206.72
<b>Condition</b>	Hardened off by heat

## Mechanical Data

(Values in direction of press)

<b>Tensile strength RM</b>	min. 245 N/mm <sup>2</sup>
<b>Elastic limit RP 0.2</b>	195 N/mm <sup>2</sup>
<b>Ductile yield</b>	min 10%
<b>Modulus of elasticity</b>	70 kN/mm <sup>2</sup>
<b>Brinell hardness</b>	75 HB
<b>Thermal expansion 20-100 °C</b>	23.4 · 10 <sup>-6</sup> / °C
<b>Density</b>	2.7 kg/dm <sup>3</sup>

## Tolerances

Production related deviations in regards to straightness, flatness and twist but also outside and t-slot dimensions are in accordance with the standard DIN EN 12020: 9001 part 2.

## Surface Treatment

<b>Anodized to</b>	E6 / EV1 (natural) E6 / EV6 (black)
<b>Coating thickness</b>	ca. 15 µm
<b>Coating hardness</b>	250-350 HV
<b>RAL colours powder coating (on request)</b>	

## Supplied Lengths

(according to DIN EN 12020 part 2)

Requirements for exact extrusion lengths should be communicated with your order. Standard 3 m or 6 m length extrusions may be slightly longer due to production related requirements.

# Manufacturing Tolerances

## Tolerances Of External Dimensions and T-Slot Positions

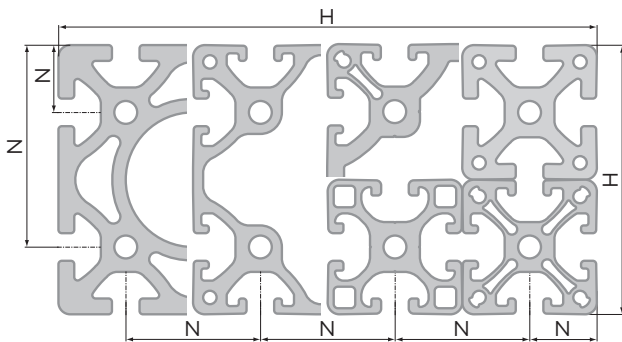

Width H (mm)		Tolerances of external dimension H or rather t-slot position N ± (mm)
over	to	
0	10	0.10
10	20	0.15
20	40	0.20
40	60	0.30
60	80	0.40
80	100	0.45
100	120	0.50
120	160	0.60
160	240	0.80

## T-Slot Dimension Tolerances

The strong, double bridge, semi, light and superlight series profiles possess a standardised t-slot shape. This guarantees that all fasteners and accessories can be utilised with the different profile series and sizes.

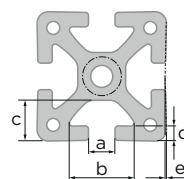

Gauge	
a	8.20 ±0.1
b	20.00 ±0.1
c	12.40 ±0.2
d	4.50 ±0.1
e	0.20 ±0.1

### Center Holes

The center hole bore of the profiles can be opened up according to the table. Profiles of the series superlight, however, may not be opened up due to the wall section around the center hole.

Drilling	
d1	Ø 6.8-0.2 (M8)
Up to max. d2	Ø 13 (M12) (not for superlight)

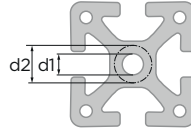

### NV Profile T-Slot

The NV t-slot is not pretensioned. The NV profile range has been designed for use with gauge plates and linear bearings, that require the profile surface to be flat. E.g. jigs, fixtures and special purpose machines.

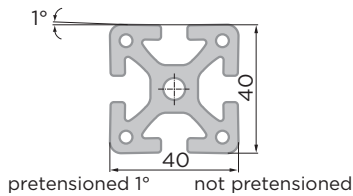

### Drilling Position Tolerances

The drilling position tolerance is dependent upon the number of the center hole bores and the contour of the profile.

Profiles with open t-slots	
Number of drillings	Z (mm)
1	0.4
2 to 4	0.6
> 4	0.8

Profiles with closed t-slots	
Number of drillings	Z (mm)
1	0.6
> 1	0.8

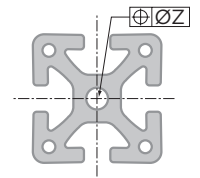

### T-Slot Strength

Information in regards to the maximum allowable t-slot load capability F. These values already include a safety factor (S > 2) against plastic deformation.

Profile	Max. pull charge F
Strong	5000 N
Double bridge	3250 N
Semi	2500 N
Light	2000 N
Superlight	1750 N



**Torsion**

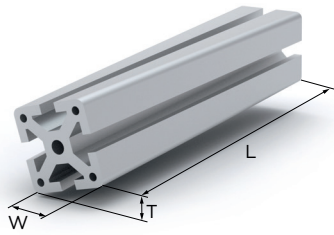

Width W (mm)		Torsion tolerance T (mm) for nominal length L (mm)					
over	to	to 1000	to 2000	to 3000	to 4000	to 5000	to 6000
-	25	1.0	1.5	1.5	2.0	2.0	2.0
25	50	1.0	1.2	1.5	1.8	2.0	2.0
50	75	1.0	1.2	1.2	1.5	2.0	2.0
75	100	1.0	1.2	1.5	2.0	2.2	2.5
100	125	1.0	1.5	1.8	2.2	2.5	3.0
125	150	1.2	1.5	1.8	2.2	2.5	3.0
150	200	1.5	1.8	2.2	2.6	3.0	3.5
200	300	1.8	2.5	3.0	3.5	4.0	4.5

**Straightness Tolerance**

Transverse

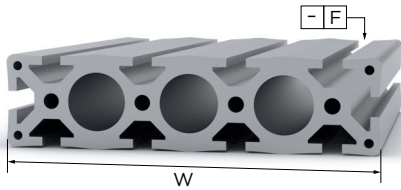

Width W (mm)		Straightness tolerance F (mm)
over	to	
0	30	0.20
30	60	0.30
60	100	0.40
100	150	0.50
150	200	0.70
200	250	0.85

**Straightness Tolerance**

Longitudinal

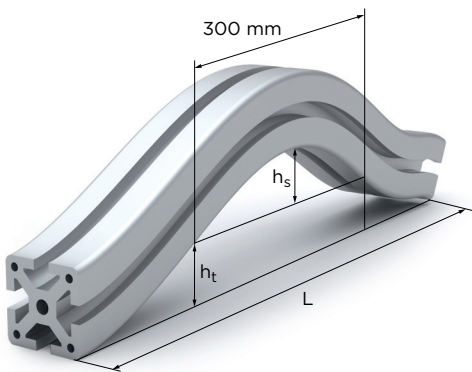

Length L (mm)	Straightness tolerance $h_t$ for nominal length L (mm)
to 1000	0.7
to 2000	1.3
to 3000	1.8
to 5000	2.2
to 5000	2.6
to 6000	3.0

The straightness tolerance  $h_t$  is in relation to a corresponding length L and will not exceed the stated value in the table. The straightness tolerance  $h_s$  will not exceed 0.3 mm per 300 mm in length.

**Angle Tolerance**

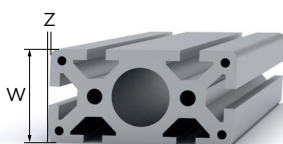

Width W (mm)		Permissible deflection Z (mm) from a right angle
over	to	
0	20	0.2
20	40	0.4
40	80	0.6
80	120	0.8
120	200	1.2
	200	1.5

## Evaluation of Deflection

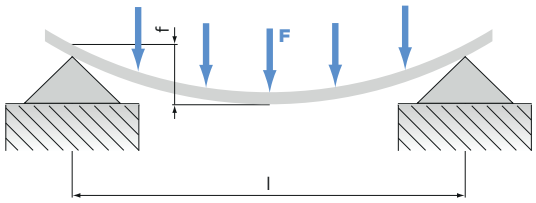
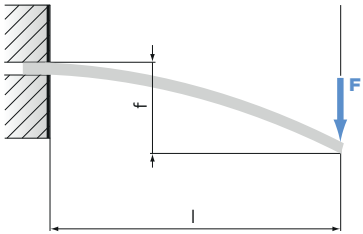
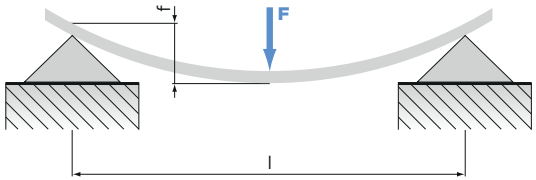
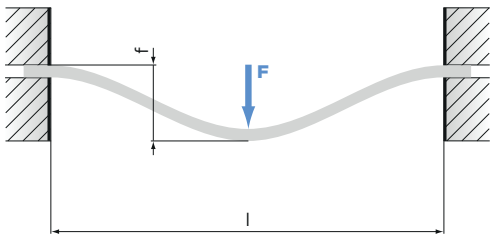
	Calculation deflection	Calculation deflection, caused by dead weight
 <p>Exposure Case 1 (on two stilts, distributed load)</p>	$f = \frac{5 \cdot F \cdot L^3}{384 \cdot E \cdot I \cdot 10^4}$	$f = \frac{5 \cdot F \cdot L^3}{384 \cdot E \cdot I \cdot 10^4}$
 <p>Exposure Case 2 (fixed one-sided, point load)</p>	$f = \frac{F \cdot L^3}{3 \cdot E \cdot I \cdot 10^4}$	$f = \frac{F \cdot L^3}{8 \cdot E \cdot I \cdot 10^4}$
 <p>Exposure Case 3 (on two stilts, point load)</p>	$f = \frac{F \cdot L^3}{48 \cdot E \cdot I \cdot 10^4}$	$f = \frac{5 \cdot F \cdot L^3}{384 \cdot E \cdot I \cdot 10^4}$
 <p>Exposure Case 4 (fixed two-sided, point load)</p>	$f = \frac{F \cdot L^3}{192 \cdot E \cdot I \cdot 10^4}$	$f = \frac{F \cdot L^3}{384 \cdot E \cdot I \cdot 10^4}$

- F = Load (N)
- L = Profile length (mm)
- I = Moment of inertia (cm<sup>4</sup>)
- E = Modulus of elasticity (N/mm<sup>2</sup>)
- EAI = 70,000 N/mm<sup>2</sup>

**Control of the Deflection**

$$s = \frac{M_b}{W \cdot 10^3}$$

s = Deflection (N/mm<sup>2</sup>)

M<sub>b</sub> = Maximum bending (N/mm)

W = Resistive moment (cm<sup>3</sup>)

**Example**

Known values: Profile 40 x 80 double bridge, upright

F = 10,000 N

L = 500 mm

I = 73.74 cm<sup>4</sup>

**Results**

Exposure Case 1: f = 1.17 mm

Exposure Case 2: f = 8.07 mm

Exposure Case 3: f = 0.50 mm

Exposure Case 1: f = 0.126 mm

to calculate: deflection f





**ALWAYS THE RIGHT  
SOLUTION AT THE RIGHT TIME.**

With reliability, competence and commitment Rollco rapidly delivers the right solutions and components to create safe and cost-effective automation and linear movement.

**ROLLCO**

LINEAR SOLUTIONS **YOUR WAY**

**Rollco AB**

Box 22234  
Ekvändan 3  
250 24 Helsingborg  
Sweden  
Tel. +46 42 15 00 40  
[www.rollco.se](http://www.rollco.se)

**Rollco A/S**

Skomagervej 13 E  
7100 Vejle  
Denmark  
Tel. +45 75 52 26 66  
[www.rollco.dk](http://www.rollco.dk)

**Rollco Oy**

Sarankulmankatu 12  
33900 Tampere  
Finland  
Tel. +358 207 57 97 90  
[www.rollco.fi](http://www.rollco.fi)

**Rollco Norge AS**

Industrigata 6  
3414 Lierstrada  
Norway  
Tel. +47 32 84 00 34  
[www.rollco.no](http://www.rollco.no)